



**CHB&CQB Chassis Mount/Din-Rail With  
Heat Sink 33 to 150 WATT  
Application Note V12 July 2017**

**ISOLATED DC-DC CONVERTER  
Half/Quarter Brick 33 to 150 WATT  
CHASSIS MOUNT/Din-Rail  
APPLICATION NOTE**



**Approved By:**

Department	Approved By	Checked By	Written By
Research and Development Department	Enoch	Astray	Joyce
		Jacky	
Quality Assurance Department	David	Benny	



**CHB&CQB Chassis Mount/Din-Rail With  
Heat Sink 33 to 150 WATT  
Application Note V12 July 2017**

---

**Contents**

1. Ordering Information .....	3
2. DC-DC Converter Features .....	3
3. Recommend External Capacitor .....	4
4. Terminal Block .....	4
4-1. Half Brick Module .....	4
4-2. Quarter Brick Module .....	4
5 Power Derating .....	5
5-1. Half Brick Module .....	5
5-2. Quarter Brick Module .....	8
6. Heat Sinks .....	11
6.1 Half Brick Heat Sinks: .....	11
6.2 Quarter Brick Heat Sinks: .....	12
6. Mechanical Specifications .....	13
6.1 Mechanical Outline Diagrams .....	13



# CHB&CQB Chassis Mount/Din-Rail With Heat Sink 33 to 150 WATT Application Note V12 July 2017

## 1. Ordering Information

CHB(E)XXX-	XX	S	XX	N	-XXX	+X-XXXX
Model No.	Nominal Input Voltage	Single Output	Output Voltage	Remote On/Off	CM: Chassis Mount DIN: Din Rail Mount	Heat Sink Type (Option)
CHB50W CHB75W CHE75W CHB100W CHE100W	24 : 24VDC 48 : 48VDC		3V3/33: 3.3VDC 05: 5VDC 12: 12VDC 15: 15VDC 24: 24VDC 48: 48VDC	None: Positive Logic N: Negative Logic		M-C308 M-C091 M-C092
CHB50W CHB75W CHB100W			28: 28VDC			

CQB(E)XXX-	XX	S	XX	N	-XXX	+X-XXXX
Model No.	Nominal Input Voltage	Single Output	Output Voltage	Remote On/Off	CM: Chassis Mount DIN: Din Rail Mount	Heat Sink Type (Option)
CQE50W CQB75W CQB100W	24: 24VDC 48: 48VDC		3V3 : 3.3VDC 05 : 5VDC 12 : 12VDC 15 : 15VDC 24 : 24VDC	None: Positive Logic N: Negative Logic		M-C448 M-C421
CQE50W			48 : 48VDC			
CQB100	110: 110VDC		05 : 5VDC 12 : 12VDC 24 : 24VDC			
CQB150W	24: 24VDC 48: 48VDC 110: 110VDC		12 : 12VDC 24 : 24VDC 28 : 28VDC 48 : 48VDC			

## 2. DC-DC Converter Features

- 33-150W Isolated Output
- 4:1 Wide Input Range
- Chassis Mount/Din Rail Mount
- Input Over Voltage Protection
- Regulated Outputs
- Continuous Short Circuit Protection
- CE Mark Meet 2014/30/EU
- Safety Meets UL60950-1, EN60950-1, and IEC60950-1
- UL60950-1 Approval for DC Modules  
(Excludes CHE75W, CHE100W and 28Vout)



# CHB&CQB Chassis Mount/Din-Rail With Heat Sink 33 to 150 WATT Application Note V12 July 2017

### 3. Recommend External Capacitor

Require input and output aluminum capacitor connected in the table below.

MODEL NUMBER	INPUT	OUTPUT
CHB50W-XXSXX-CM/DIN	NC	47uF/100V for 48Vout Models Only
CHB75W-XXSXX-CM/DIN	47uF/100V for 48Vin Models	47uF/100V for 48Vout Models Only
CHE75W-XXSXX-CM/DIN	100uF/100V	10uF/100V for 48Vout Models Only
CHB100W-XXSXX-CM/DIN	100uF/100V for 24Vin Models 47uF/100V for 48Vin Models	47uF/100V for 48Vout Models Only
CHE100W-XXSXX-CM/DIN	220uF/100V	10uF/100V for 48Vout Models Only

MODEL NUMBER	INPUT
CQE50W-XXSXX-CM/DIN	220uF/100V for 24Vin Models 47uF/100V for 48Vin Models
CQB75W-XXSXX-CM/DIN	220uF/100V for 24Vin Models
CQB100W-XXSXX-CM/DIN	100uF/100V for 24Vin Models 47uF/100V for 48Vin Models
CQB100-110SXX-CM/DIN	120uF/200V
CQB150W-XXSXX-CM/DIN	470uF/50V for 24Vin Models 220uF/100V for 48Vin Models 220uF/200V for 110Vin Models

NOTE:

1. Short JP1 to connect +S and +Vo, JP2 to connect -S and -Vo with local sense.
2. Remove jumper( JP1& JP2),terminal block port +S,-S & Trim can be used to Output Remote Sensing or Output Voltage Adjustment functional(see application note).
3. Thermal resistance is referenced to the application note.
4. Include TVS for input surge voltage protection.
5. Recommend external fuse for input reverse polarity protection (Include shunt diode inside).
6. Suffix "DIN" to the Model number with din mount, the clip is suitable for TS-35 din rail.

### 4. Terminal Block

#### 4-1. Half Brick Module

Input and Output Terminal Block

Terminal Type	Screw Torque Value (Kgf-cm)	Suitable Electric Wire (AWG)	Current Rating (max.)
DT-49-B01WXX or Equivalent	10	12-22	25A

Remote On/Off, Sense Terminal Block

Terminal Type	Screw Torque Value (Kgf-cm)	Suitable Electric Wire (AWG)	Current Rating (max.)
EK508V-XXP or Equivalent	5	16-30	13.5A

#### 4-2. Quarter Brick Module

Input and Output Terminal Block

Terminal Type	Screw Torque Value (Kgf-cm)	Suitable Electric Wire (AWG)	Current Rating (max.)
EK500V-XXP or Equivalent	5	12-24	20A



# CHB&CQB Chassis Mount/Din-Rail With Heat Sink 33 to 150 WATT

## Application Note V12 July 2017

### 5 Power Derating

#### 5-1. Half Brick Module

The operating case temperature range of CHE100W series is  $-40^{\circ}\text{C}$  to  $+105^{\circ}\text{C}$ . When operating the CHE100W series, proper derating or cooling is needed. The maximum case temperature under any operating condition should not exceed  $105^{\circ}\text{C}$ .

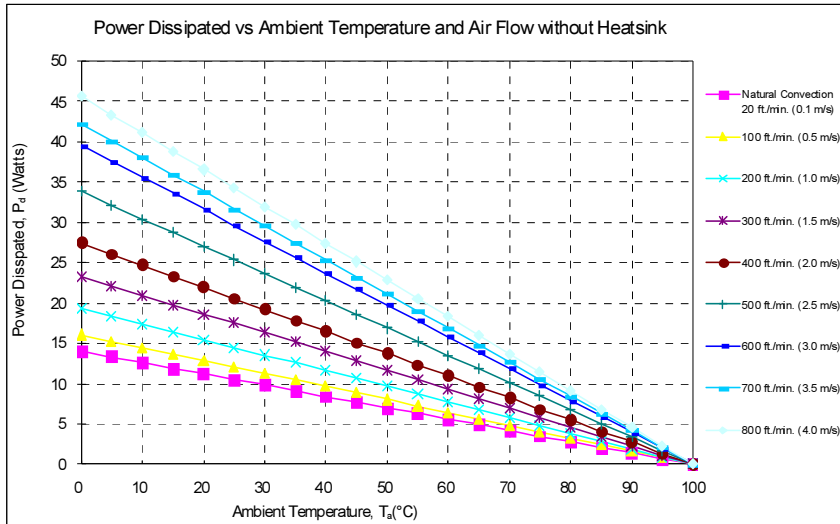

AIR FLOW RATE	TYPICAL $R_{ca}$
Natural convection	$7.12^{\circ}\text{C/W}$
20ft./min. (0.1m/s)	
100 ft./min. (0.5m/s)	$6.21^{\circ}\text{C/W}$
200 ft./min. (1.0m/s)	$5.17^{\circ}\text{C/W}$
300 ft./min. (1.5m/s)	$4.29^{\circ}\text{C/W}$
400 ft./min. (2.0m/s)	$3.64^{\circ}\text{C/W}$
500 ft./min. (2.5m/s)	$2.96^{\circ}\text{C/W}$
600 ft./min. (3.0m/s)	$2.53^{\circ}\text{C/W}$
700 ft./min. (3.5m/s)	$2.37^{\circ}\text{C/W}$
800 ft./min. (4.0m/s)	$2.19^{\circ}\text{C/W}$

#### Example:

What is the minimum airflow necessary for a CHE100W-48S12-CM/DIN operating at nominal line voltage, an output current of 8.4A, and a maximum ambient temperature of  $50^{\circ}\text{C}$ ?

#### Solution:

##### Given:

$$V_{in}=48V_{dc}, V_o=12V_{dc}, I_o=8.4A$$

##### Determine Power dissipation ( $P_d$ ):

$$P_d = P_i - P_o = P_o(1-\eta)/\eta$$

$$P_d = 12V \times 8.4A \times (1-0.93)/0.93 = 7.59\text{Watts}$$

##### Determine airflow:

$$\text{Given: } P_d = 7.59\text{W and } T_a = 50^{\circ}\text{C}$$

##### Check Power Derating curve:

$$\text{Minimum airflow} = 100 \text{ ft./min.}$$

##### Verify:

Maximum temperature rise is

$$\Delta T = P_d \times R_{ca} = 7.59\text{W} \times 6.21 = 47.13^{\circ}\text{C.}$$

Maximum case temperature is

$$T_c = T_a + \Delta T = 97.13^{\circ}\text{C} < 105^{\circ}\text{C.}$$

##### Where:

The  $R_{ca}$  is thermal resistance from case to ambient environment.

$T_a$  is ambient temperature and  $T_c$  is case temperature.



# CHB&CQB Chassis Mount/Din-Rail With Heat Sink 33 to 150 WATT

## Application Note V12 July 2017

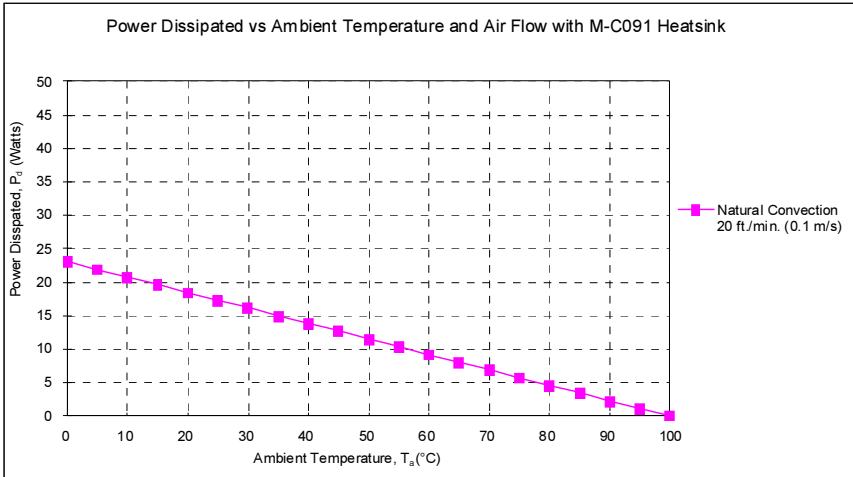

AIR FLOW RATE	TYPICAL $R_{ca}$
Natural convection 20ft./min. (0.1m/s) for CM/DIN	4.33°C/W

### Example (with heatsink M-C091):

What is the minimum airflow necessary for a CHE100W-48S12 operating at nominal line voltage, an output current of 8.4A, and a maximum ambient temperature of 65°C.

#### Solution:

#### Given:

$$V_{in}=48V_{dc}, V_o=12V_{dc}, I_o=8.4A$$

#### Determine Power dissipation ( $P_d$ ):

$$P_d=P_i-P_o=P_o(1-\eta)/\eta$$

$$P_d=12 \times 8.4 \times (1-0.93)/0.93=7.59\text{Watts}$$

#### Determine airflow:

$$\text{Given: } P_d=7.59\text{W and } T_a=65^\circ\text{C}$$

#### Check above Power derating curve:

Natural Convection

#### Verify:

Maximum temperature rise is

$$\Delta T = P_d \times R_{ca}=7.59\text{W} \times 4.33=32.86^\circ\text{C}$$

Maximum case temperature is

$$T_c=T_a+\Delta T=97.86^\circ\text{C} < 105^\circ\text{C}$$

#### Where:

The  $R_{ca}$  is thermal resistance from case to ambient environment.

$T_a$  is ambient temperature and  $T_c$  is case temperature.



# CHB&CQB Chassis Mount/Din-Rail With Heat Sink 33 to 150 WATT

## Application Note V12 July 2017

### Half Brick Module

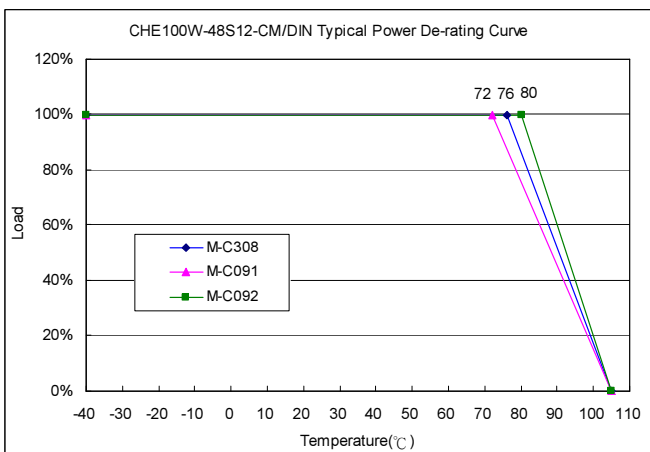
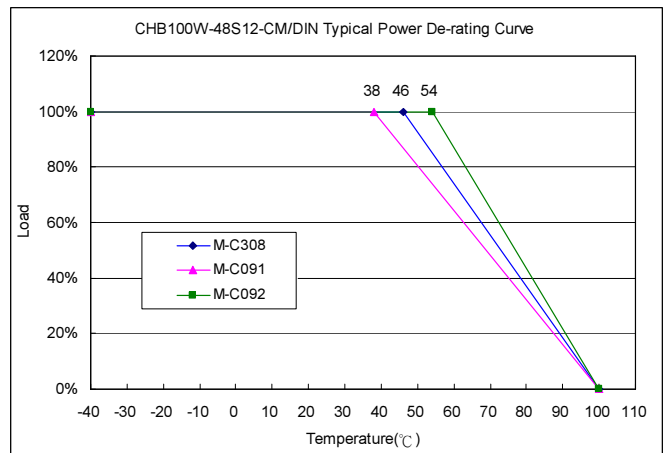
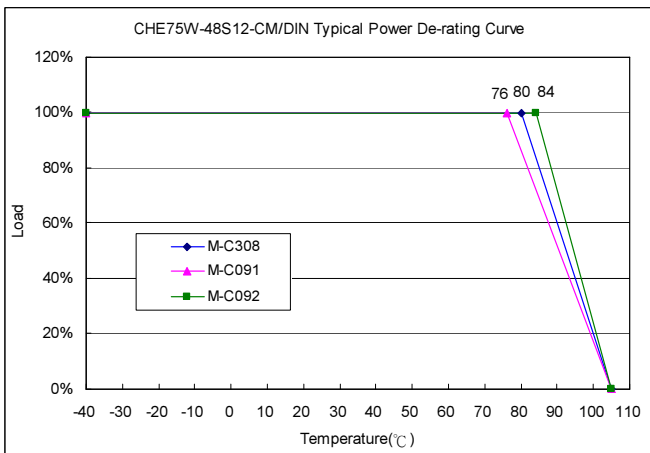
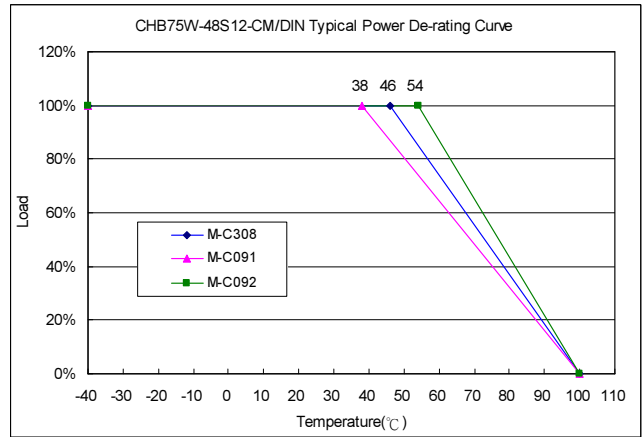
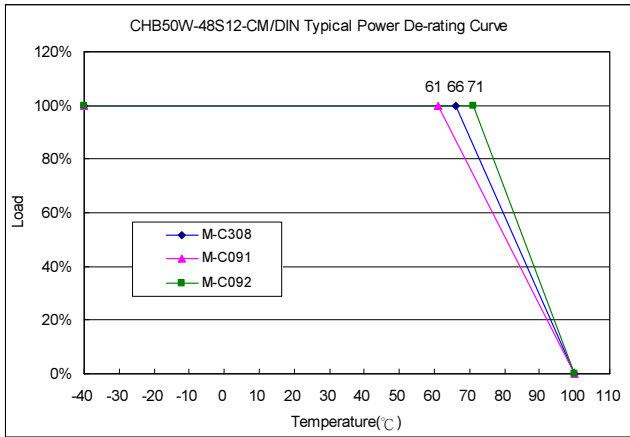



# CHB&CQB Chassis Mount/Din-Rail With Heat Sink 33 to 150 WATT Application Note V12 July 2017

## 5-2. Quarter Brick Module

The operating case temperature range of CQB100W series is  $-40^{\circ}\text{C}$  to  $+100^{\circ}\text{C}$ . When operating the CQB100W series, proper de-rating or cooling is needed. The maximum case temperature under any operating condition should not exceed  $100^{\circ}\text{C}$ .

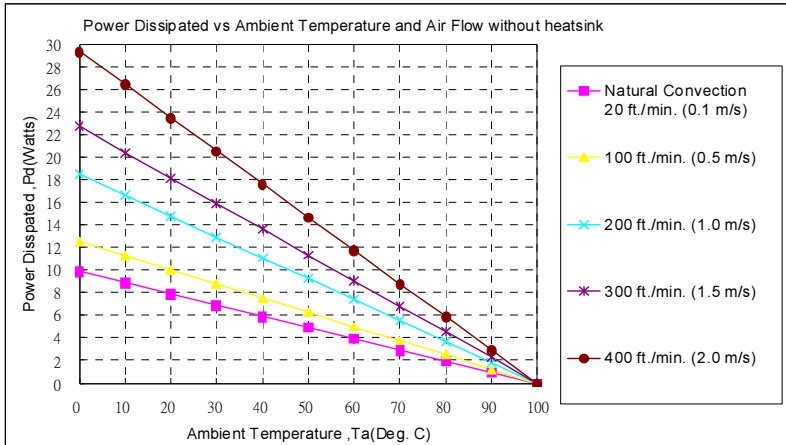

AIR FLOW RATE	TYPICAL $R_{ca}$
Natural Convection 20ft./min. (0.1m/s)	10.1 $^{\circ}\text{C}/\text{W}$
100 ft./min. (0.5m/s)	8.0 $^{\circ}\text{C}/\text{W}$
200 ft./min. (1.0m/s)	5.4 $^{\circ}\text{C}/\text{W}$
300 ft./min. (1.5m/s)	4.4 $^{\circ}\text{C}/\text{W}$
400 ft./min. (2.0m/s)	3.4 $^{\circ}\text{C}/\text{W}$

### Example (without heatsink):

What is the minimum airflow necessary for a CQB100W-48S12-CM/DIN operating at nominal line voltage, an output current of 8.3A, and a maximum ambient temperature of  $35^{\circ}\text{C}$ ?

#### Solution:

#### Given:

$$V_{in}=48V_{dc}, V_o=12V_{dc}, I_o=8.3A$$

#### Determine Power dissipation ( $P_d$ ):

$$P_d=P_i-P_o=P_o(1-\eta)/\eta$$

$$P_d=12 \times 8.3 \times (1-0.88)/0.88=13.58\text{Watts}$$

#### Determine airflow:

$$\text{Given: } P_d=13.58\text{W and } T_a=35^{\circ}\text{C}$$

#### Check above Power de-rating curve:

Minimum airflow = 300 ft./min.

#### Verify:

Maximum temperature rise is

$$\Delta T = P_d \times R_{ca}=13.58 \times 4.4=59.8^{\circ}\text{C}$$

Maximum case temperature is

$$T_c=T_a+\Delta T =94.8^{\circ}\text{C} < 100^{\circ}\text{C}$$

#### Where:

The  $R_{ca}$  is thermal resistance from case to ambient environment.

$T_a$  is ambient temperature and  $T_c$  is case temperature





# CHB&CQB Chassis Mount/Din-Rail With Heat Sink 33 to 150 WATT Application Note V12 July 2017

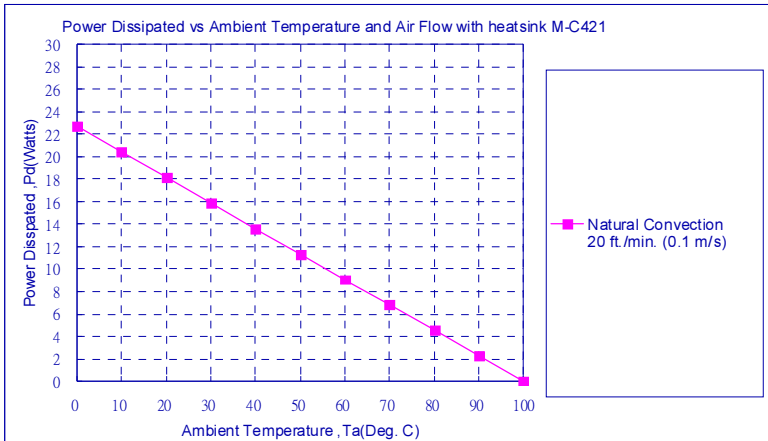

AIR FLOW RATE	TYPICAL R <sub>ca</sub>
Natural Convection 20ft./min. (0.1m/s) for CM/DIN	4.41 °C/W

**Example (with heatsink M-C421):**

What is the minimum airflow necessary for a CQB100W-48S12 operating at nominal line voltage, an output current of 8.3A, and a maximum ambient temperature of 35°C?

**Solution:**

**Given:**

$$V_{in}=48V_{dc}, V_o=12V_{dc}, I_o=8.3A$$

**Determine Power dissipation (P<sub>d</sub>):**

$$P_d = P_i - P_o = P_o(1-\eta)/\eta$$

$$P_d = 12 \times 8.3 \times (1-0.88)/0.88 = 13.58 \text{ Watts}$$

**Determine airflow:**

Given: P<sub>d</sub>=13.58W and T<sub>a</sub>=35°C

**Check above Power de-rating curve:**

Natural Convection

**Verify:**

Maximum temperature rise is

$$\Delta T = P_d \times R_{ca} = 13.58 \times 4.41 = 59.9^\circ\text{C}$$

Maximum case temperature is

$$T_c = T_a + \Delta T = 94.9^\circ\text{C} < 100^\circ\text{C}$$

**Where:**

The R<sub>ca</sub> is thermal resistance from case to ambient environment.

T<sub>a</sub> is ambient temperature and T<sub>c</sub> is case temperature



# CHB&CQB Chassis Mount/Din-Rail With Heat Sink 33 to 150 WATT

## Application Note V12 July 2017

### Quarter Brick Module

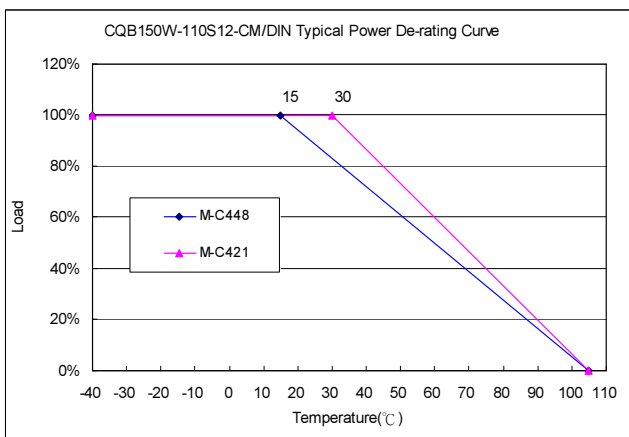
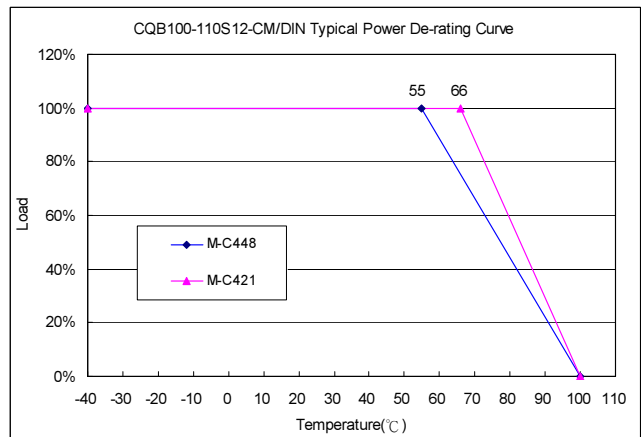
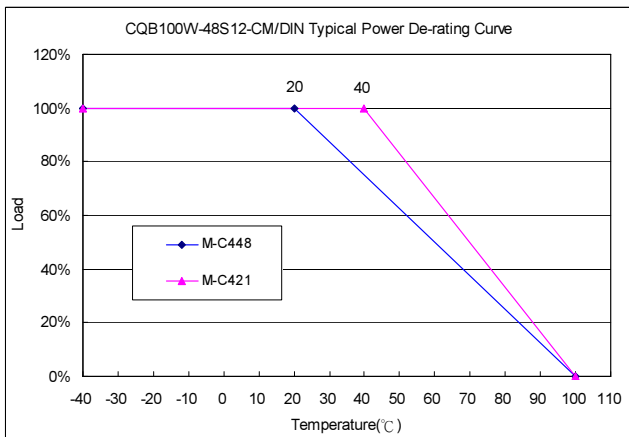
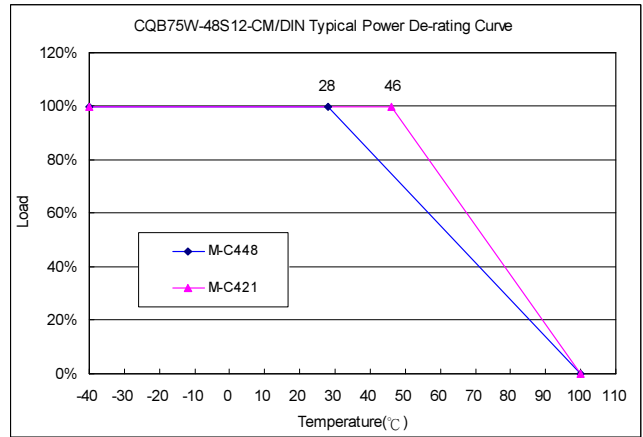
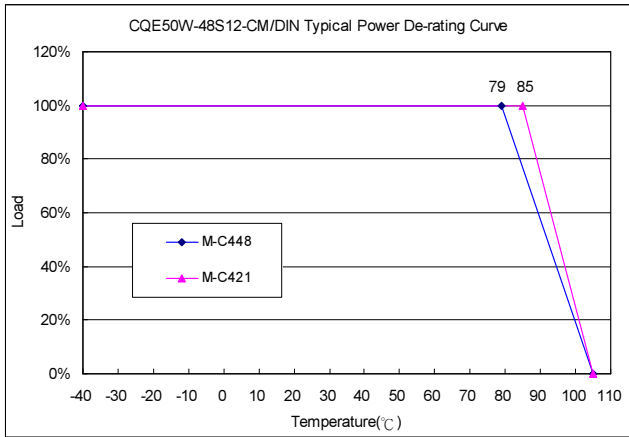



# CHB&CQB Chassis Mount/Din-Rail With Heat Sink 33 to 150 WATT

## Application Note V12 July 2017

### 6. Heat Sinks

#### 6.1 Half Brick Heat Sinks:

All Dimensions in mm

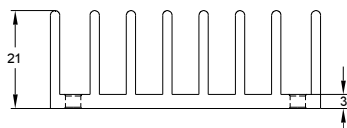
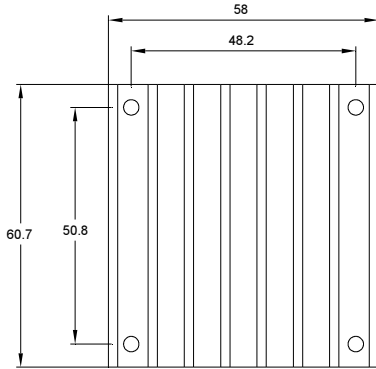

**M-C308**

Longitudinal Heat Sink

**Rca (for CM/DIN):**

3.78°C/W (typ.), natural convection

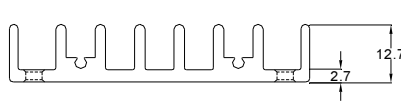
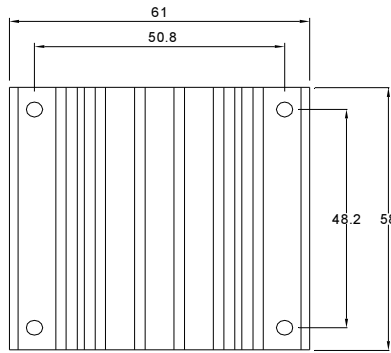

**M-C091**

Transverse Heat Sink

**Rca (for CM/DIN):**

4.33°C/W (typ.), natural convection

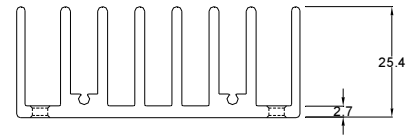
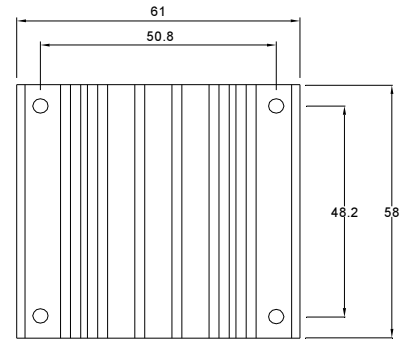

**M-C092**

Transverse Heat Sink

**Rca (for CM/DIN):**

3.21°C/W (typ.), natural convection

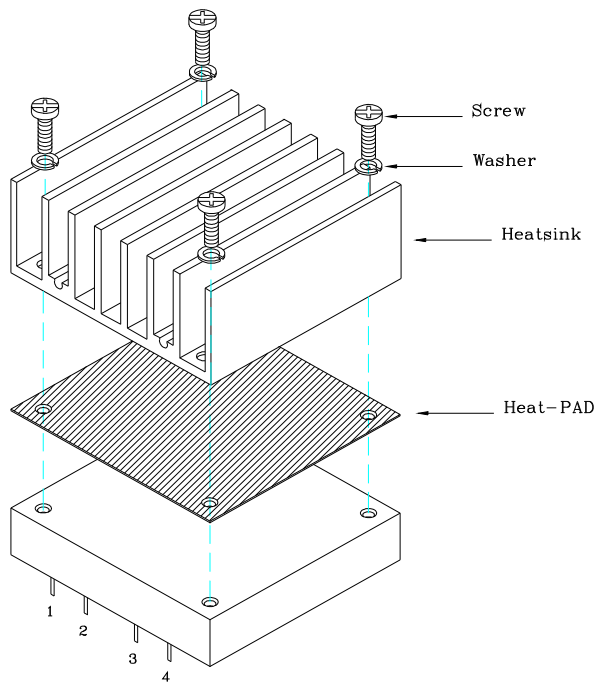

THERMAL PAD: SZ 56.9\*60\*0.25 mm (G6135041091 )  
 SCREW: SMP+SW M3\*8L (G75A1300322 )



# CHB&CQB Chassis Mount/Din-Rail With Heat Sink 33 to 150 WATT

## Application Note V12 July 2017

### 6.2 Quarter Brick Heat Sinks:

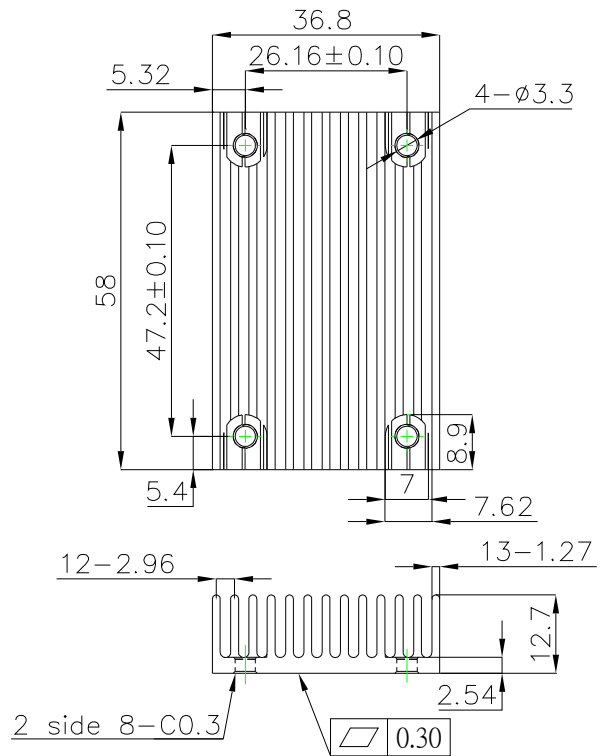
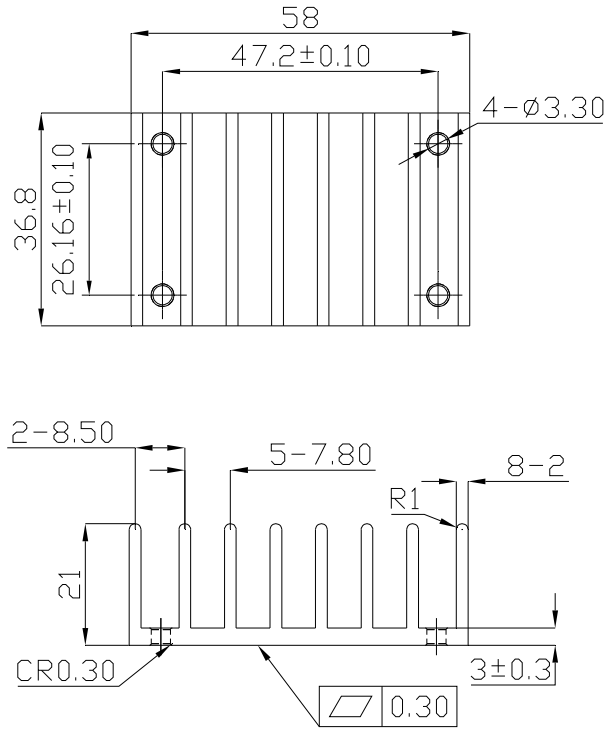

All Dimensions in mm

#### M-C421 (G6620510201) Transverse Heat Sink

- Rca: 4.78°C/W (typ.), At natural convection
- 2.44°C/W (typ.), At 100LFM
- 2.06°C/W (typ.), At 200LFM
- 1.76°C/W (typ.), At 300LFM
- 1.58°C/W (typ.), At 400LFM

#### M-C448 (G6620570202) Longitudinal Heat Sink

- Rca: 5.61°C/W (typ.), At natural convection
- 4.01°C/W (typ.), At 100LFM
- 3.39°C/W (typ.), At 200LFM
- 2.86°C/W (typ.), At 300LFM
- 2.49°C/W (typ.), At 400LFM

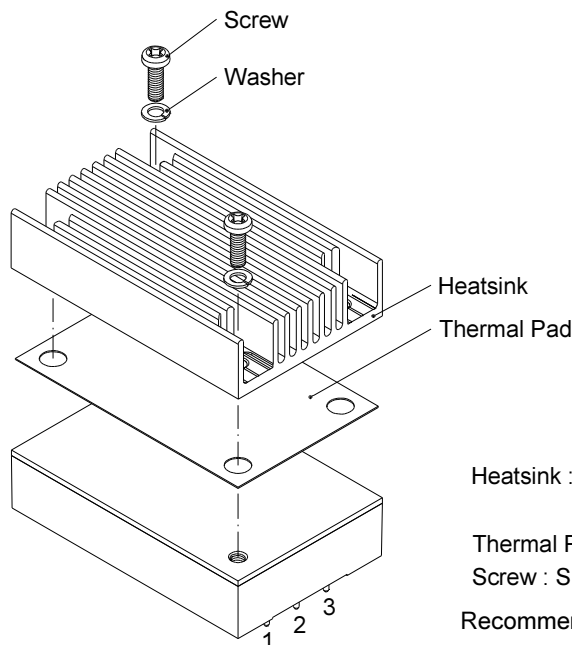

- Heatsink : M-C448
- M-C421
- Thermal Pad : SZ35.8x56.9x0.25mm
- Screw : SMP+SW M3x8L
- Recommended torque 3 Kgf-cm



# CHB&CQB Chassis Mount/Din-Rail With Heat Sink 33 to 150 WATT

## Application Note V12 July 2017

### 6. Mechanical Specifications

#### 6.1 Mechanical Outline Diagrams

##### Half Brick Module

All Dimensions In Inches[mm]  
 Tolerance Inches:x.xx= ±0.02, x.xxx= ±0.010  
 Millimeters:x.x= ±0.5, x.xx=±0.25

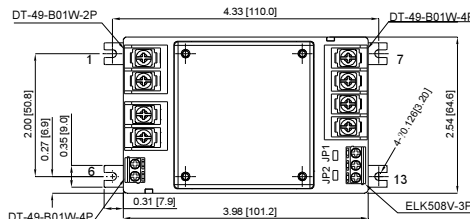
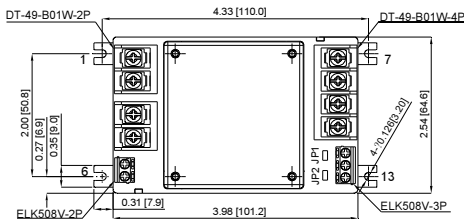

PIN CONNECTIONS			
PIN	FUNCTION	PIN	FUNCTION
1,2	+V Input	11	+Sense
3,4	-V Input	12	Trim
5	On/Off	13	-Sense
6	Case	JP1	Short +S&+Vo
7,8	+V Output	JP2	Short -S&-Vo
9,10	-V Output		

Suffix -CM (Left Side) / Suffix -DIN(Right Side)

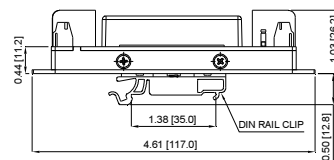
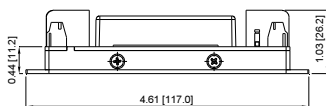

##### Quarter Brick Module

All Dimensions In Inches[mm]  
 Tolerance Inches:x.xx= ±0.02, x.xxx= ±0.010  
 Millimeters:x.x= ±0.5, x.xx=±0.25

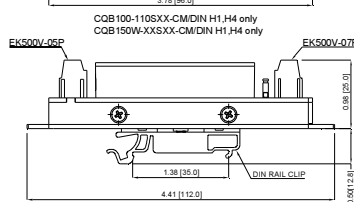
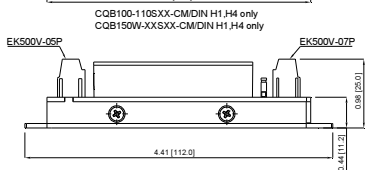
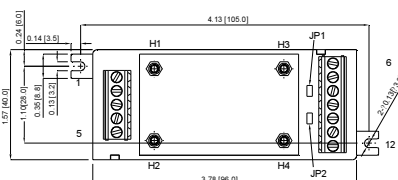
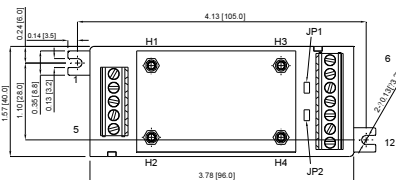

PIN CONNECTIONS			
PIN	FUNCTION	PIN	FUNCTION
1,2	+V Input	10	-Sense
3	On/Off	11,12	-V Output
4,5	-V Input	JP1	Short +S&+Vo
6,7	+V Output	JP2	Short -S&-Vo
8	+Sense		
9	Trim		

Suffix -CM (Left Side) / Suffix -DIN(Right Side)

### CINCON ELECTRONICS CO., LTD.

#### Headquarters:

14F, No.306, Sec.4, Hsin Yi Rd.  
 Taipei, Taiwan  
 Tel: 886-2-27086210  
 Fax: 886-2-27029852  
 E-mail: [support@cincon.com.tw](mailto:support@cincon.com.tw)  
 Web Site: <http://www.cincon.com>

#### Factory:

No. 8-1, Fu Kung Rd.  
 Fu Hsing Industrial Park  
 Fu Hsing Hsiang,  
 Chang Hua Hsien, Taiwan  
 Tel: 886-4-7690261  
 Fax: 886-4-7698031

#### Cincon North America:

1655 Mesa Verde Ave. Ste 180  
 Ventura, CA 93003  
 Tel: 805-639-3350  
 Fax: 805-639-4101  
 E-mail: [info@cincon.com](mailto:info@cincon.com)