



LFM550S SERIES 550 WATT AC-DC POWER SUPPLY WITH PFC

Features

- Universal Input Range 85~264Vac
- High Efficiency up to 94%
- Class I
- 25.4mm Low Profile Package
- Approval IEC/EN/UL 62368-1 Ed 3.0
- Approval EN 55032 and CISPR/FCC Class B
- Meets IEC/EN 60335-1
- Operating Altitude 5000m
- Continuous Short Circuit Protection
- Over Voltage Protection
- Over Temperature Protection
- High Power Density 36.66W/Inches³
- Active PFC Function
- Over Voltage Category OVC II & OVC III



MODEL NUMBER	OUTPUT VOLTAGE	OUTPUT CURRENT			RIPPLE & NOISE NOTE1	VOLTAGE ACCURACY NOTE2	VOLTAGE ADJ. RANGE	LINE REGULATION NOTE3	LOAD REGULATION NOTE4	% EFF. (Typ.) NOTE5
		With Fan NOTE6	With Conduction Cooling NOTE7							
			Baseplate	Cover						
LFM550S120	12 V	45.83 A	29.17 A	37.5 A	120 mV	±1%	11.4-12.6 V	±0.3%	±0.5%	92%
LFM550S150	15 V	36.66 A	23.33 A	30 A	150 mV	±1%	14.25-15.75 V	±0.3%	±0.5%	93%
LFM550S240	24 V	22.91 A	14.58 A	18.75 A	200 mV	±1%	22.8-25.2 V	±0.3%	±0.5%	93%
LFM550S280	28 V	19.64 A	12.5 A	16.07 A	200 mV	±1%	28-29.4 V	±0.3%	±0.5%	93%
LFM550S300	30 V	18.33 A	11.66 A	15 A	200 mV	±1%	28.5-31.5 V	±0.3%	±0.5%	93%
LFM550S360	36 V	15.27 A	9.72 A	12.5 A	200 mV	±1%	34.2-37.8 V	±0.3%	±0.5%	94%
LFM550S480	48 V	11.45 A	7.29 A	9.37 A	200 mV	±1%	45.6-50.4 V	±0.3%	±0.5%	94%
LFM550S540	54 V	10.18 A	6.48 A	8.34 A	200 mV	±1%	51.3-56.7 V	±0.3%	±0.5%	94%

Note:

1. Add a 0.1uF ceramic capacitor and a 10uF E.L. capacitor to output for ripple & noise measuring @20MHz BW.
2. Voltage accuracy is set at full load.
3. Line regulation is measured from 100Vac to 240Vac with full load.
4. Load regulation is measured from 10% to 100% full load.
5. Typical efficiency at 230 Vac and full load at 25°C.
6. Forced air convection with 21.9CFM above 110Vac.
7. With addition cooling conduction plate, 38.1 by 38.1 cm with min. 0.2 cm thick, as below.



LFM550S Series

PART NUMBER

Series	Number of Outputs	Nominal Output Voltage	Type	Mounting Inserts
LFM550	O	XXX	X	-YZ
LFM550	S : Single	120 : 12V 150 : 15V 240 : 24V 280 : 28V 300 : 30V 360 : 36V 480 : 48V 540 : 54V	B : With Baseplate C : With Cover	Blank : Through Hole C0 : Threaded Hole

Part Number Example:

LFM550S120C-C0: With Cover 200W, Single 12Vdc Output, Threaded Hole

LFM550S240B: With Baseplate 200W, Single 24Vdc Output, Through Hole



LFM550S Series

TECHNICAL SPECIFICATIONS

(All specifications are typical at nominal input, full load at 25°C unless otherwise noted.)

ABSOLUTE MAXIMUM RATINGS

PARAMETER	NOTES and CONDITIONS	Device	Min.	Typ.	Max.	Units
Input Voltage	Safety approvals only to the AC input	All	85 115		264 370	V _{ac} V _{dc}
Operating Temperature	See derating curve	All	-40		80	°C
Operating Case Temperature	At the center of base plate (T _c = Case temperature)	All	-40		90	°C
Storage Temperature		All	-40		90	°C
Operating Altitude	IEC/EN/UL 62368-1 OVC II IEC/EN/UL 62368-1 OVC III	All			5000 2000	m

INPUT CHARACTERISTICS

PARAMETER	NOTES and CONDITIONS	Device	Min.	Typ.	Max.	Units
Operating Voltage Range		All	100		240	V _{ac}
Input Frequency Range		All	47		63	Hz
Maximum Input Current	100% Load, V _{in} =100V _{ac}	All			6.3	A
Leakage Current	Contact leakage current Earth leakage current	All			100 300	uA
Inrush Current	V _{in} =240V _{ac} , Cold Start @25°C	All			45	A
Power Factor	230V _{ac} @ Full load	All	0.96	0.98		

OUTPUT CHARACTERISTICS

PARAMETER	NOTES and CONDITIONS	Device	Min.	Typ.	Max.	Units
Output Voltage Set Point	V _{in} =Nominal V _{in} , I _o =I _o max., T _c =25°C	LFM550S120	11.88	12	12.12	V _{dc}
		LFM550S150	14.85	15	15.15	
		LFM550S240	23.76	24	24.24	
		LFM550S280	27.72	28	28.28	
		LFM550S300	29.7	30	30.3	
		LFM550S360	35.64	36	36.36	
		LFM550S480	47.52	48	48.48	
Operating Output Current Range	V _{in} =85V _{ac} ~264V _{ac} , see derating curve	LFM550S120	0		45.83	A
		LFM550S150	0		36.66	
		LFM550S240	0		22.91	
		LFM550S280	0		19.64	
		LFM550S300	0		18.33	
		LFM550S360	0		15.27	
		LFM550S480	0		11.45	
LFM550S540	0		10.18			
Holdup Time	V _{in} =115V _{ac}	All	8	12		ms
Output Voltage Regulation						
Load Regulation	10% Load to full load	All			±0.5	%
Line Regulation	V _{in} =High line to low line	All			±0.3	%
Output Voltage Adjustment	P _o ≤ max. rated power, I _o ≤ I _o max.	LFM550S280	0		+5	%
		Others	-5		+5	



LFM550S Series

PARAMETER	NOTES and CONDITIONS	Device	Min.	Typ.	Max.	Units
Over Voltage Protection	Latch off (AC recycle to reset)	LFM550S120			16	V _{dc}
		LFM550S150			20	
		LFM550S240			32	
		LFM550S280			35	
		LFM550S300			35	
		LFM550S360			45	
		LFM550S480			55	
		LFM550S540			60	
Over Current Protection	Auto recovery (output is rated load)	All	120	140	160	%
Short Circuit Protection	Auto recovery	All				
Over Temperature Protection	Auto recovery	All				
Output Ripple and Noise	1. Add a 0.1uF ceramic capacitor and a 10uF aluminum electrolytic capacitor to output 2. Oscilloscope is 20MHz band width. 3. Ambient Temperature=25°C	LFM550S120			120	mV
		LFM550S150			150	
		LFM550S240			200	
		LFM550S280			200	
		LFM550S300			200	
		LFM550S360			200	
		LFM550S480			200	
		LFM550S540			200	
Load Capacitance	1. V _{in} =115V _{ac} and 230V _{ac} 2. Output is max. load 3. Ambient temperature=25°C	LFM550S120			27200	uF
		LFM550S150			22400	
		LFM550S240			14100	
		LFM550S280			11600	
		LFM550S300			10600	
		LFM550S360			9020	
		LFM550S480			7200	
		LFM550S540			6000	
Efficiency	1. Input Voltage is 230Vac 2. Output is rated load 3. Ambient temperature=25°C	LFM550S120		92		%
		LFM550S150		93		
		LFM550S240		93		
		LFM550S280		93		
		LFM550S300		93		
		LFM550S360		94		
		LFM550S480		94		
		LFM550S540		94		

ISOLATION CHARACTERISTICS

PARAMETER	NOTES and CONDITIONS	Device	Min.	Typ.	Max.	Units
Input to Output	1 Minute (without dielectric breakdown)	All			4250	V _{ac}
Input to Earth (Ground)	1 Minute (without dielectric breakdown)	All			2000	V _{ac}
Output to Earth (Ground)	1 Minute (without dielectric breakdown)	All			2000	V _{ac}
Isolation Resistance	Input to output	All	100			MΩ

FEATURE CHARACTERISTICS

PARAMETER	NOTES and CONDITIONS	Device	Min.	Typ.	Max.	Units
Switching Frequency		All		65		kHz



LFM550S Series

GENERAL SPECIFICATIONS

PARAMETER	NOTES and CONDITIONS	Device	Min.	Typ.	Max.	Units
MTBF	I _o =100%; T _a =25°C per MIL-HDBK-217F I _o =100%; T _a =25°C per Telcordia SR332	All	400		1300	k hours
Life Time (Detail refer to Application Note)	Conduction cooling @75% Load, 40°C	All		97		k hours
	Fan cooling @75% Load, 40°C			150		
Humidity	Non-condensing	All			93	% RH
Shock	Meet MIL-STD-810F Table 516.5, Table 516.5-1 10ms, each axis 3 times(±X、±Y、±Z axis)	All		75		g
Vibration	Meet MIL-STD-810F Table 514.5C-VIII, 15~2000Hz, X、Y、Z axis, 1 hour (each axis), Total 3 hrs.	All		4		g
Weight	Baseplate versions	LFM550SXXXB		380		grams
	Covered versions	LFM550SXXXC		535		
Dimensions	Baseplate versions	LFM550SXXXB	5.00x3.00x1.00 Inches (127.0x76.2x25.4 mm)			
	Covered versions	LFM550SXXXC	5.09x3.29x1.00 Inches (129.4x83.5x25.4 mm)			
Safety	Class I, IEC/EN/UL 62368-1					Ed. 3.0
EMC Emission	EN 55032, EN 61000-6-4, EN 61204-3, EN 61000-3-2, EN 61000-3-3, 47 CFR FCC Part 15					
Conducted Disturbance	EN 55032, 47 CFR FCC Part 15					Class B
Radiated Disturbance	EN 55032, 47 CFR FCC Part 15					Class B
Harmonic Current Emissions	EN 61000-3-2					Class A, C, D
Voltage Fluctuations & Flicker	EN 61000-3-3					Criterion A
EMC Immunity	EN 55035, EN 61000-6-2, EN 61204-3					
Electrostatic Discharge (ESD)	IEC 61000-4-2, Level 3: Air Discharge: ±8kV, Level 2: Contact Discharge: ±4kV					Criterion A
Radio-Frequency, Continuous Radiated Disturbance	IEC 61000-4-3, Level 3: 80~2700MHz, 10V/m					Criterion A
Electrical Fast Transient (EFT)	IEC 61000-4-4, Level 3: ±2kV					Criterion A
Surge	IEC 61000-4-5, Level 4: L-N: ±2kV, L-E (Ground): ±4kV					Criterion A
Conducted Disturbances, Induced by RF Fields	IEC 61000-4-6, Level 3: 0.15~80MHz, 10V					Criterion A
Power Frequency Magnetic Field	IEC 61000-4-8, Level 4: 30A/m					Criterion A
Voltage Dips	IEC/EN 61000-4-11, Dip: 30% Reduction					Criterion A
	IEC/EN 61000-4-11, Dip >95% Reduction					
Voltage Interruptions	IEC/EN 61000-4-11, >95% Reduction					Criterion B
Application Note Link						LFM550S Series App Notes



LFM550S Series

CHARACTERISTIC CURVE

Power Derating Curve

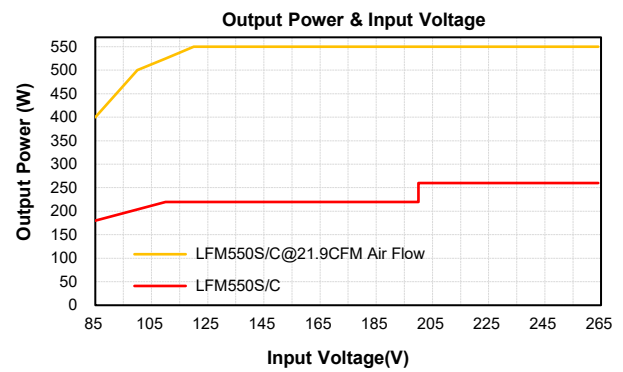
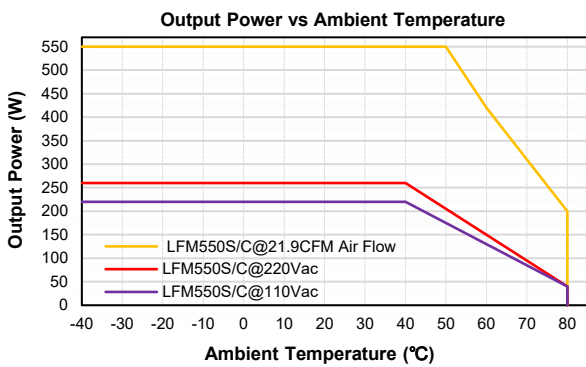
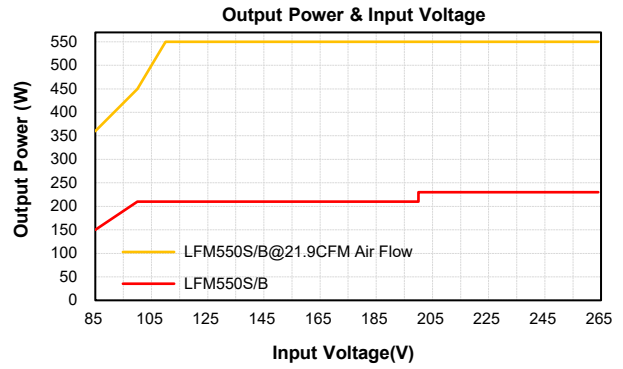
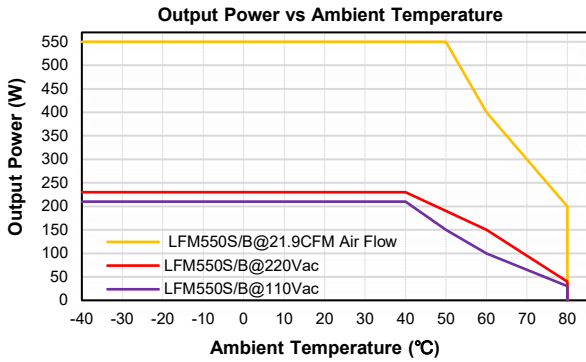



LFM550S Series

Conduction Convection with External Baseplate (38.1cmx38.1cmx0.2cm)

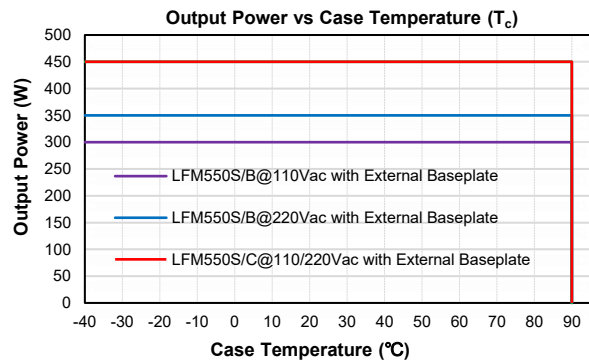
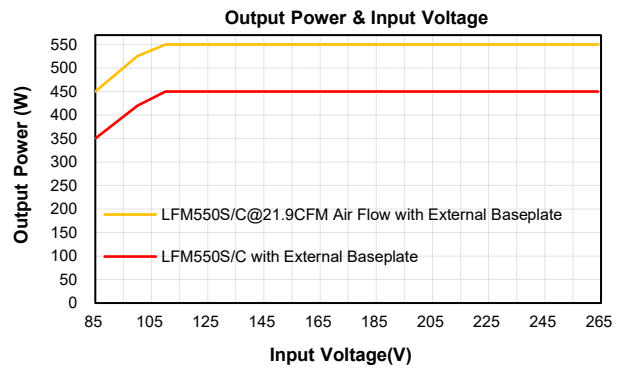
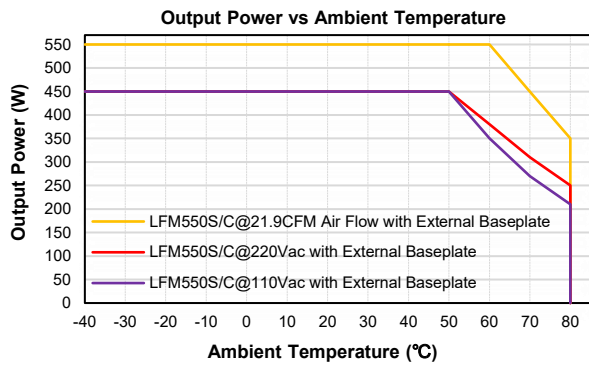
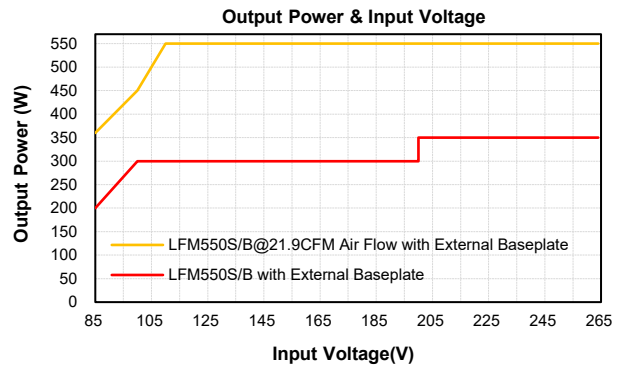
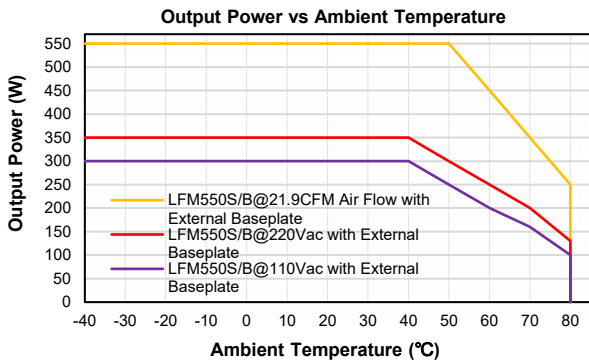



LFM550S Series

Performance Data

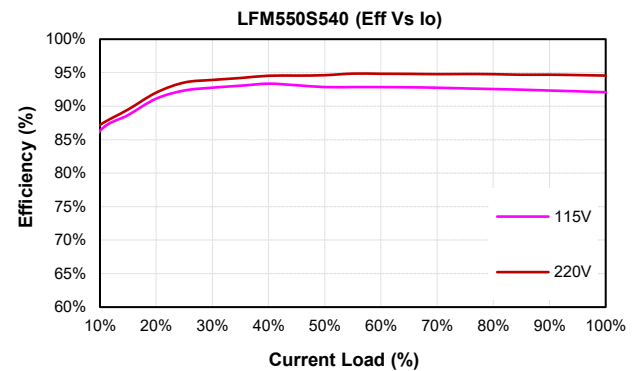
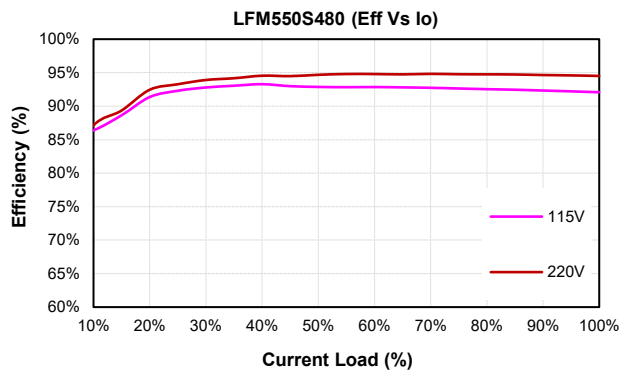
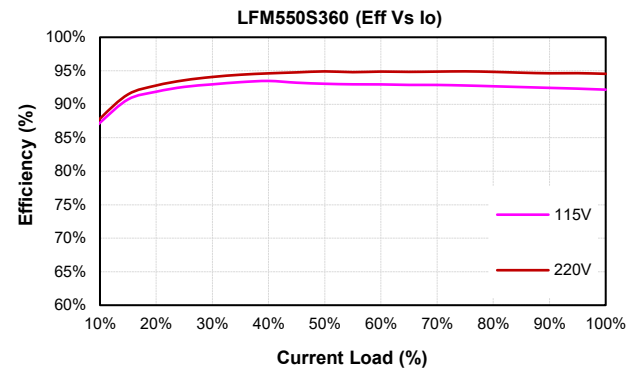
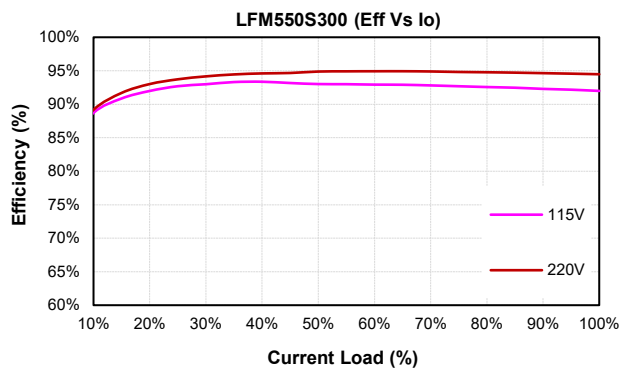
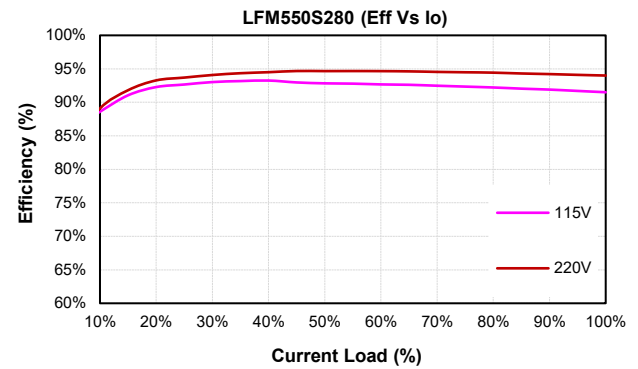
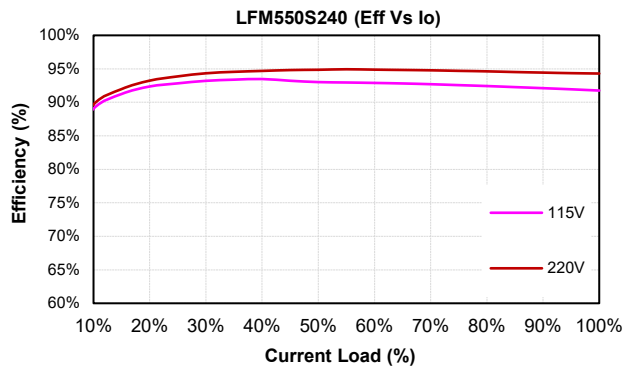
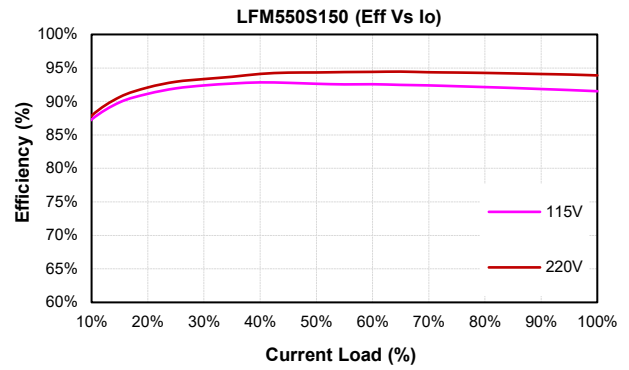
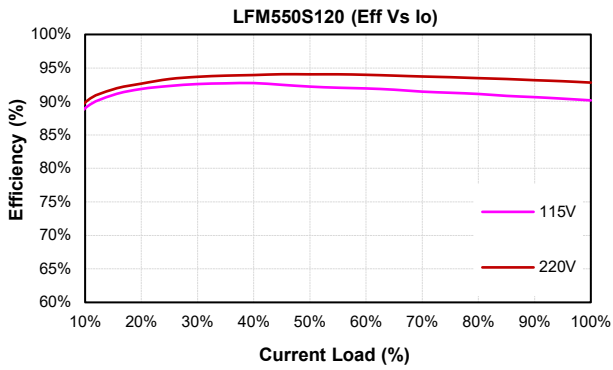



LFM550S Series

MECHANICAL SPECIFICATION

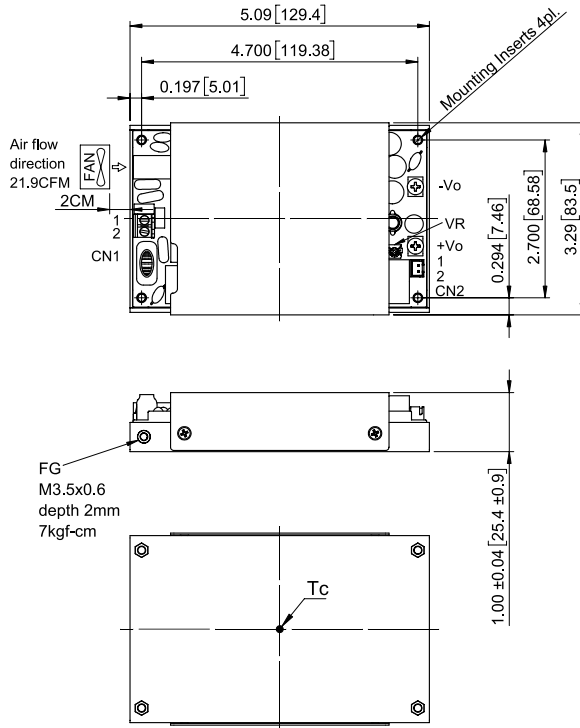

LFM550SXXXC LFM550SXXXC-C0

All Dimensions in Inches[mm]
Tolerance Inches: x.xx=±0.03, x.xxx=±0.020
Millimeters: x.x=±0.7, x.xx=±0.50

AC Input Connector(CN1):ECE ETB22

Pin	Function	Mating Wire Range
1	ACL	14~16 AWG
2	ACN	

DC Output Connector(CN2):TKP 8822-02-NHB or equivalent

Pin	Function	Mating Housing	Terminal
1	Rs+	JST XHP-2 or equivalent	JST SXH-001T-P0.6N or equivalent
2	Rs-		

DC Output Connector:KANG YANG PCB-58M4

Function	The screw locked torque
+Vo	M4 7kgf-cm
-Vo	

Mounting Inserts

Series	Option
Blank	∅3.2 Through depth 10.5mm
-C0	M3x0.5 Threaded depth 10.5mm

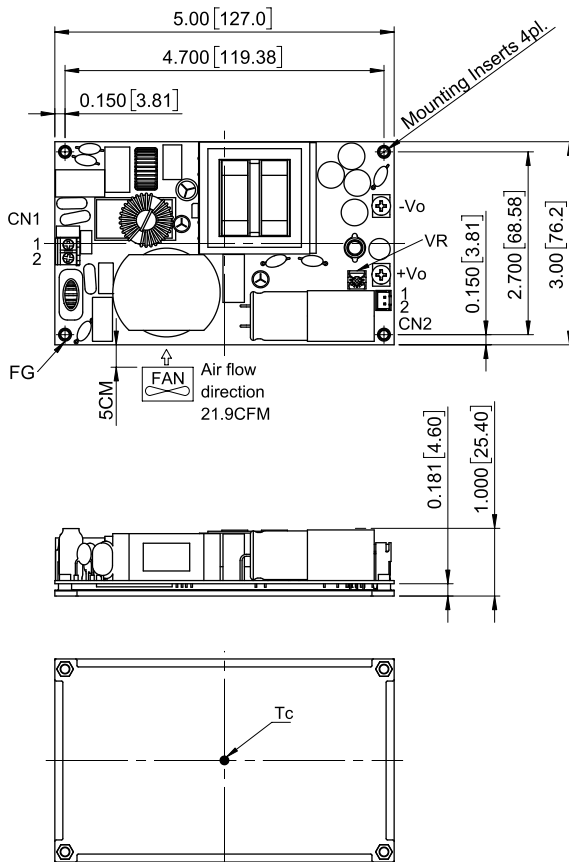

LFM550SXXXB LFM550SXXXB-C0

All Dimensions in Inches[mm]
Tolerance Inches: x.xx=±0.03, x.xxx=±0.020
Millimeters: x.x=±0.7, x.xx=±0.50

AC Input Connector(CN1):ECE ETB22

Pin	Function	Mating Wire Range
1	ACL	14~16 AWG
2	ACN	

DC Output Connector(CN2):TKP 8822-02-NHB or equivalent

Pin	Function	Mating Housing	Terminal
1	Rs+	JST XHP-2 or equivalent	JST SXH-001T-P0.6N or equivalent
2	Rs-		

DC Output Connector:KANG YANG PCB-58M4

Function	The screw locked torque
+Vo	M4 7kgf-cm
-Vo	

Mounting Inserts

Series	Option
Blank	∅3.2 Through depth 8.1mm
-C0	M3x0.5 Threaded depth 8.1mm

CINCON Electronics Co. Ltd.
Add: 14F, No. 306, Sec.4, Hsin Yi Rd., Taipei, Taiwan
Tel: 886-2-27086210
Fax: 886-2-27029852
E-mail: sales@cincon.com.tw
Web: www.cincon.com