



PFC750 Application Note V10

AC-DC BRICK PFC MODULE PFC750 APPLICATION NOTE



Approved By:

Department	Approved By	Checked By	Written By
Research and Development Department	Enoch	Tim	Shane
		Ovid	
Design Quality Department	Benny	JoJo	



PFC750

Application Note V10

Contents

1. Introduction	3
2. Pin Function Description	3
3. Electrical Block Diagram	3
4. Connection for Standard Use	4
5. Test Set-Up	4
6. Features and Functions	4
6.1 Over Voltage Protection	4
6.2 Over Temperature Protection	4
6.3 Power Good Function	4
6.4 Sequence Chart	5
7. Input / Output Considerations	5
7.1 Input EMI Filter at the Power Module	5
7.2 Hold Up Time	5
7.3 Inrush Current Limiting Resistor TRF1	6
7.4 Output Ripple and Noise	6
7.5 Output Capacitance	6
8. Thermal Design	7
8.1 Operating Temperature Range	7
8.2 Convection Requirements for Cooling	7
8.3 Thermal Consideration	7
8.4 Power Derating	7
8.5 Half Brick Heat Sink	9
9. Packing Information	10



PFC750

Application Note V10

1. Introduction

The PFC750 module is an industry standard half-brick AC-DC converter with PFC function, it can provide 750W output power at 390VDC output voltage.

High efficiency up to 96.5% and power factor up to 0.99, allowing case operating temperature range of -40°C to 100°C. An optional heat sink is available to extend the full power range of the unit. Fully protected against input BNI/BNO(Brown-In/Brown-Out), output over-voltage and over-temperature.

2. Pin Function Description

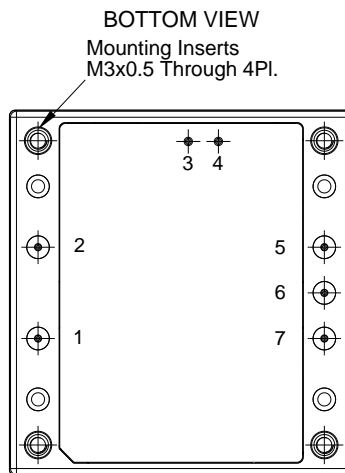

No	Label	Function	Description
1	AC1	AC Input	AC supply input.
2	AC2	AC Input	
3	AUX	Auxiliary Power	Offer an auxiliary 13VDC output.
4	ENA	Power Good	When power is ready, this pin will be pulled low ; otherwise, it will be open.
5	-Vo	-V Output	Negative power output.
6	R	Inrush Current Limit	Inrush current can be reduced by external resistor.
7	+Vo	+V Output	Positive power output.
--	--	Mounting Insert	Mounting insert (FG)

Note: Base plate can be connected to FG through M3 threaded mounting insert. Recommended torque 4-8Kgf-cm.

3. Electrical Block Diagram

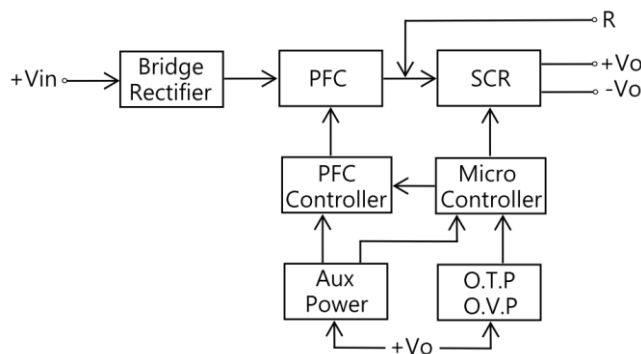



PFC750

Application Note V10

4. Connection for Standard Use

The connection for standard use is shown below. An external EMI filter is recommended to reduce electrical noise. The bus capacitors (C1 and C2) are recommended to set 330uF (KMR series of NCC) or more. The TRF1 is used to limit input inrush current.

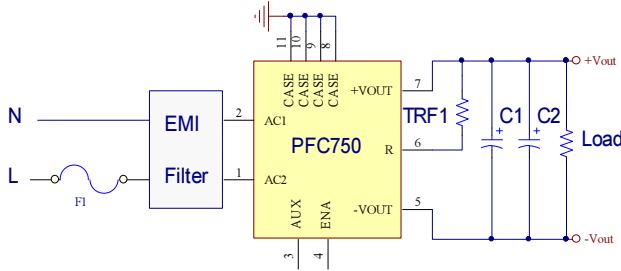

Symbol	Component
F1	Input fuse
EMI Filter	External EMI filter on the input side
TRF1	External thermal fuse resistor
C1, C2	External capacitor connected between +Vout and -Vout is necessary to keep stable.

5. Test Set-Up

The basic test set-up to measure parameters such as efficiency and regulation is shown below. When testing the PFC750 under any transient conditions, please ensure that the transient response of the source is sufficient to power the equipment. We can calculate:

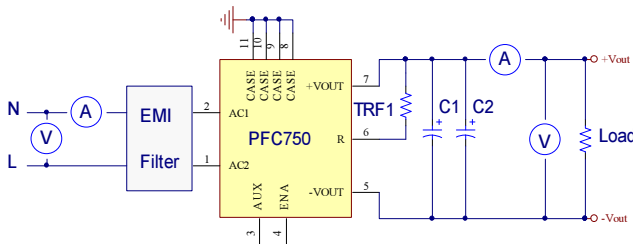

The value of efficiency is defined as:

$$\eta = \frac{V_o \times I_o}{V_{in} \times I_{in}} \times 100\%$$

Where:

V_o is output voltage

I_o is output current

V_{in} is input voltage

I_{in} is input current

The value of load regulation is defined as:

$$Load\ reg. = \frac{V_1 - V_2}{V_2} \times 100\%$$

Where:

V_1 is the output voltage at 100% load.

V_2 is the output voltage at 10% load.

The value of line regulation is defined as:

$$Line\ reg. = \frac{V_{LL} - V_{HL}}{V_{HL}} \times 100\%$$

Where:

V_{HL} is the output voltage of maximum input voltage at full load.

V_{LL} is the output voltage of minimum input voltage at full load.

6. Features and Functions

6.1 Over Voltage Protection

This module has a continuous over voltage protection function. When output voltage reaches the condition of OVP, the converter will shut down the output until back to normal range.

6.2 Over Temperature Protection

The over temperature protection is built in this module to safeguard against thermal damage. Shutdown occurs when the maximum case temperature is exceeded. The module will restart when the case temperature falls below the recovery threshold. Please measures the case temperature at the center point of aluminum base plate.

6.3 Power Good Function

The PFC750 module provides a signal from ENA pin for power good function. The ENA pin would be pulled down to -Vout when the Vout is ready; otherwise, the pin would be open. The following circuit is an example circuit for reference.

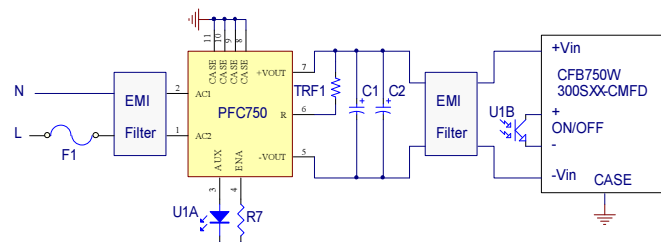



PFC750

Application Note V10

6.4 Sequence Chart

The working sequence of PFC750 is shown below.

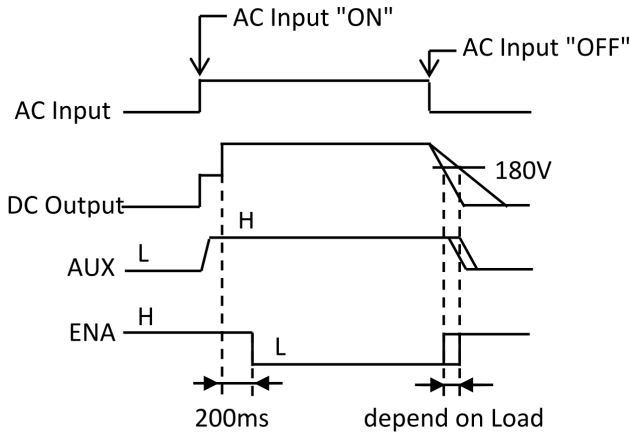

7. Input / Output Considerations

7.1 Input EMI Filter at the Power Module

Circuit as shown below represents the solution for EMI. The EMI filter should be placed close to the converter AC input pins, and the external output capacitors are chosen for suitable ripple handling capability.

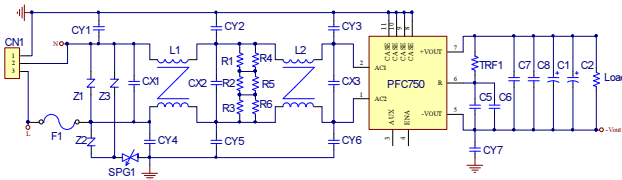

EN55032 Class A	
Model Number	
PFC750	
F1	10A 250V
Z1, Z2, Z3	φ10 470V
SA1	2500V
CX1, CX2, CX3	1.5uF/310V
C5, C6, C7, C8	0.68uF/450V
C1, C2	330uF/450V
TRF1	10R
CY1, CY2, CY3, CY4 CY5, CY6, CY7	2200pF/400Vac
CY1, CY2, CY3, CY4 CY5, CY6	Bead Core K6 T 2.54*1.27*1.27 CORE-TECH
L1	28mH
L2	2.6mH

Note:

- CX1~CX3 : X2 capacitors (CARLI MPX series) or equivalent.
- C5~8: MTF capacitors (CARLI MTF series) or equivalent.
- C1, C2 : Aluminum capacitors (NCC KMR series) or equivalent.
- CY1~CY7 : Y1 capacitors.
- CY1~CY6 : Both pin with bead core.
- F1 : Fuse.
- Z1, Z2, Z3 : Varistors (TKS TVR10471KSV) or equivalent.
- SA1 : Surge Arresters (EF2500X8S EPCOS) or equivalent.
- L1 : Common chock T25*16*8C/NANOCRYSTAL/φ 1.0mm/26T.
- L2 : Common chock T25*15*10C/R7K/φ 1.0mm/20T.
- TRF1 : Cement resistor (A5MC-100JK L3.5 A & A) or equivalent.

7.2 Hold Up Time

The capacitor C1 and C2 are used for hold up time function and output ripple current. The PFC750 supplies power to load by the energy stored in C1 and C2 when input power is interrupted.

A typical configuration as shown below.

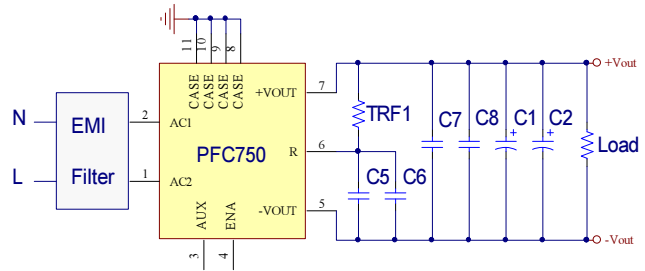

This function provides energy that maintains the output for 8ms hold up time. The capacitance in the application is recommended as follow (Allowable capacitance range: 660~2200uF).

Hold up time	Capacitance	C1 and C2
8ms		330uF



PFC750

Application Note V10

7.3 Inrush Current Limiting Resistor TRF1

TRF1 resistor is used to limit the input inrush current, and it must be connected between R and +Vout. If the resistor is not connected, the power supply will not work. TRF1 is a cement resistor with overheat protect function, it should have greater withstanding capability to Inrush Current. TRF1 is recommended to set from 4.7 to 22 Ω .

7.5 Output Capacitance

The PFC750 needs external capacitor to maintain output supply normally, the capacitance range is 660~2200uF. For good transient response, low ESR output capacitors should be located close to the output pin.

7.4 Output Ripple and Noise

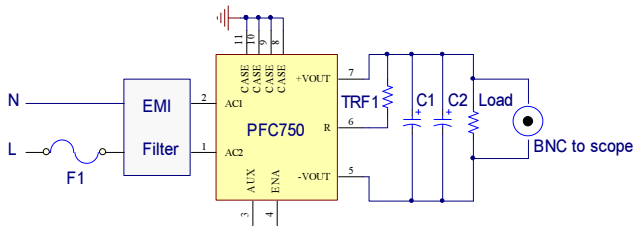

Output ripple and noise are measured with a 10uF E.L and 0.1uF ceramic capacitors across output at 20 MHz bandwidth.

The conventional ground clip on an oscilloscope probe should never be used in this kind of measurement. This clip, when placed in a field of radiated high frequency energy, acts as an antenna or inductive pickup loop, creating an extraneous voltage that is not part of the output noise of the converter.



Another method is shown below, in case of coaxial-cable/BNC is not available. The noise pickup is eliminated by pressing scope probe ground ring directly against the -Vout terminal while the tip contacts the +Vout terminal. This makes the shortest possible connection across the output terminals.

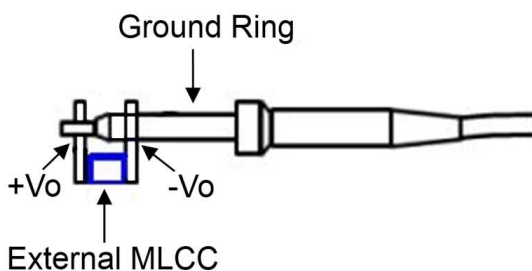



PFC750

Application Note V10

8. Thermal Design

8.1 Operating Temperature Range

The highly efficient design of Cincon's PFC750 power module could operate within case operating temperature range from -40°C to 100°C . The de-rating curve could be given when ascertaining the maximum power that can be drawn from the module. The maximum power which can be drawn is influenced by some factors, such as:

- Input voltage range
- Permissible Output load
- Forced air or natural convection
- Heat sink (optional)

8.2 Convection Requirements for Cooling

The ambient temperature and airflow are required to make sure the module temperature below its maximum rating. Once the module is assembled in the actual system, the module's temperature should be monitored to ensure it does not exceed 100°C as measured at the center of aluminum base plate.

8.3 Thermal Consideration

The power module operates in a variety of thermal environment; so sufficient cooling should be provided to help ensure reliable operation. Heat is transferred by conduction, convection and radiation to the surrounding environment. The power output of the module should not be allowed to exceed rated power ($V_{o_set} \times I_{o_max}$).

8.4 Power Derating

The operating case temperature range of PFC750 is -40°C to $+100^{\circ}\text{C}$. When operating the PFC750, proper derating and cooling are needed. The maximum case temperature under any operating condition should not exceed 100°C . The following is derating curve with heatsink.

Note1: Pd is calculated after 1 minute of burn-in

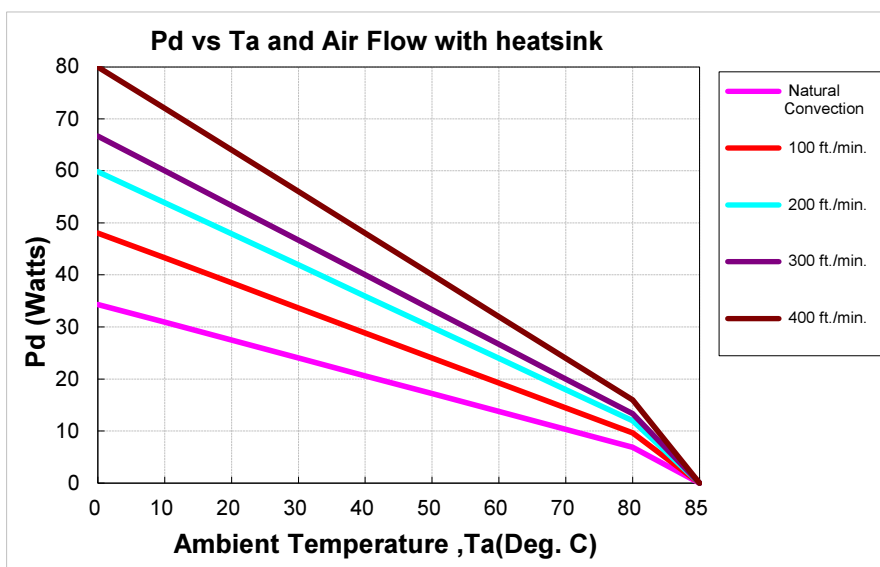

AIR FLOW RATE	TYPICAL R_{ca}
Natural Convection	$2.91^{\circ}\text{C}/\text{W}$
100 ft./min. (0.5m/s)	$2.08^{\circ}\text{C}/\text{W}$
200 ft./min. (1.0m/s)	$1.67^{\circ}\text{C}/\text{W}$
300 ft./min. (1.5m/s)	$1.50^{\circ}\text{C}/\text{W}$
400 ft./min. (2.0m/s)	$1.25^{\circ}\text{C}/\text{W}$



PFC750 Application Note V10

Example with heatsink:

What is the minimum airflow necessary for a PFC750 operating at 230Vac, output current 1.923A, and a maximum ambient temperature of 35°C without heatsink?

Solution:

Given: $V_{in}=230V_{ac}$, $V_o=390V_{dc}$, $I_o=1.923A$

Determine Power dissipation (P_d): $P_d= P_i-P_o= P_o(1-\eta)/\eta$, $P_d= 390V \times 1.923A \times (1-0.966)/0.966=26.4Watts$

Determine airflow: Given: $P_d= 26.4W$ and $T_a= 35^\circ C$

Check *Power Derating* curve: Minimum airflow= 100 ft./min.

Verify:

Maximum temperature rise is $\Delta T= P_d \times R_{ca} = 26.4 \times 2.08= 54.9^\circ C$

Maximum case temperature is $T_c = T_a + \Delta T= 89.9^\circ C < 100^\circ C$

Where:

The R_{ca} is thermal resistance from case to ambient environment.

T_a is ambient temperature and T_c is case temperature.



PFC750 Application Note V10

8.5 Half Brick Heat Sink

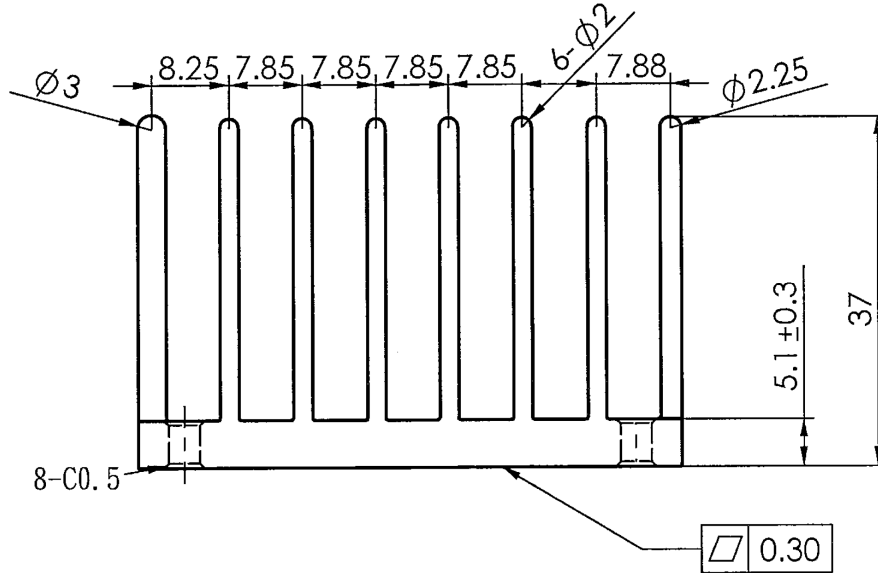

All Dimensions in mm
 Heat Sink G6620710201 60.7*58*37mm
 Rca: 2.91°C/W (typ.), At natural convection
 2.08°C/W (typ.), At 100LFM
 1.67°C/W (typ.), At 200LFM
 1.50°C/W (typ.), At 300LFM
 1.25°C/W (typ.), At 400LFM

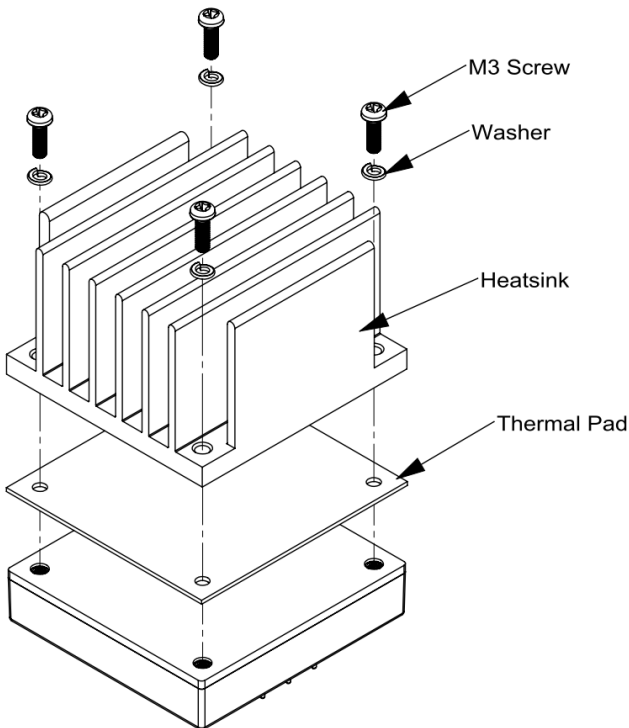

Heat Sink: 60.7*58*37mm (G6620710201)
 Thermal Pad PH01: SZ 56.9*60*0.25mm (G6135041091)
 Screw: K308W SMP+WS M3*0.5 8mm (G75A1300322)



PFC750 Application Note V10

9. Packing Information

The packing information for PFC750 is showing as follows:

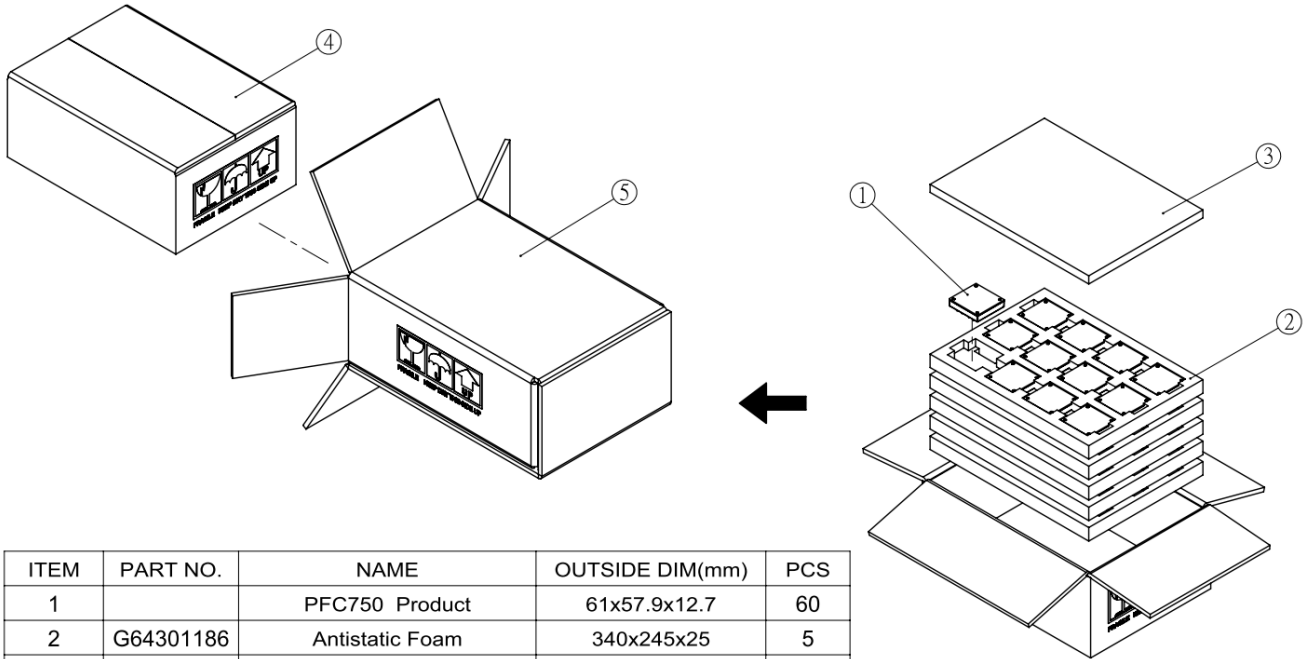

ITEM	PART NO.	NAME	OUTSIDE DIM(mm)	PCS
1		PFC750 Product	61x57.9x12.7	60
2	G64301186	Antistatic Foam	340x245x25	5
3	G64308319	Antistatic Foam	340x245x15	1
4	G64112339	No.59 Cardboard Box	360.6x257.6x148.5	1
5	G64112270	No.95 Cardboard Box	390.9x284.8x175.7	1

Each Box Packaging 60 PCS Products
Gross weight Ref. 7.2 Kg

PFC750 60 PCS a box, including the total weight of package material about 7.2Kg.

CINCON ELECTRONICS CO., LTD.

Headquarters:

14F, No.306, Sec.4, Hsin Yi Rd.
Taipei, Taiwan
Tel: 886-2-27086210
Fax: 886-2-27029852
E-mail: sales@cincon.com.tw
Web Site: <https://www.cincon.com>

Factory:

No. 8-1, Fu Kung Rd.
Fu Hsing Industrial Park
Fu Hsing Hsiang,
Chang Hua Hsien, Taiwan
Tel: 886-4-7690261
Fax: 886-4-7698031

Cincon North America:

1655 Mesa Verde Ave. Ste 180
Ventura, CA 93003
Tel: 805-639-3350
Fax: 805-639-4101
E-mail: info@cincon.com