



TRE06 Series Application Note V12

AC-DC Switching ADAPTER TRE06 Series APPLICATION NOTE



Approved By:

Department	Approved By	Checked By	Written By
Research and Development Department	Ovid	Yang/ Shih Hang	Joyce
Design Quality Department	Benny	JoJo	



TRE06 Series

Application Note V12

Content

1. INTRODUCTION	3
2. ELECTRICAL BLOCK DIAGRAM	3
3. MAIN FEATURES AND FUNCTIONS	4
3.1 <i>Operating Temperature Range</i>	4
3.2 <i>Output Current Protection</i>	4
4. APPLICATIONS	4
4.1 <i>Test Set-Up</i>	4
4.2 <i>Output Ripple and Noise Measurement</i>	4
5. PACKING INFORMATION	5



TRE06 Series

Application Note V12

1. Introduction

This application note describes the features and functions of Cincon's TRE06 series of adapter, switching AC-DC power. These are highly efficient, reliable, compact, high power density, single output AC/DC power. The power is fully protected against short circuit and over-voltage conditions. Cincon's world class automated manufacturing methods, together with an extensive testing and qualification program, ensure that the TRE06 series power is extremely reliable.

2. Electrical Block Diagram

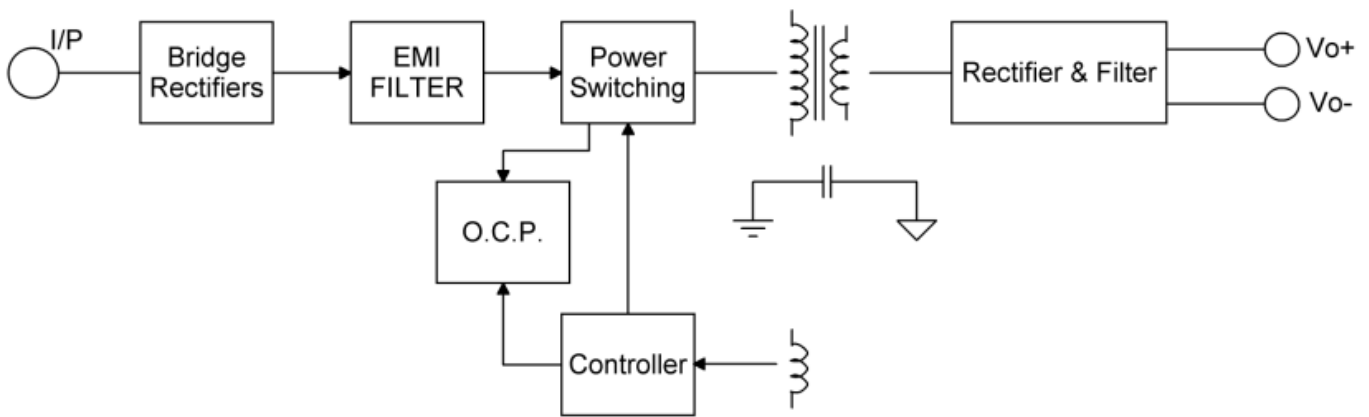



TRE06 Series

Application Note V12

3. Main Features and Functions

3.1 Operating Temperature Range

The highly efficient design of Cincon's TRE06 series power has resulted in their ability to operate within ambient temperature environments from -20°C to 80°C. Due consideration must be given to the de-rating curves when ascertaining the maximum power that can be drawn from the power. The maximum power which can be drawn is influenced by a number of factors, such as:

- Input voltage range
- Permissible output load (per derating curve)

3.2 Output Current Protection

All different voltage models have a full continuous short-circuit protection. The unit will auto recover once the short circuit is removed. To provide protection in a fault condition, the unit is equipped with internal over-current protection. The unit operates normally once the fault condition is removed. The power module will supply up to 120-140% of rated current. In the event of an over current converter will go into a hiccup mode protection

4. Applications

4.1 Test Set-Up

The basic test set-up to measure parameters such as efficiency and load regulation is shown in Figure 1. When testing the Cincon's TRE06 series under any transient conditions, please ensure that the transient response of the source is sufficient to power the equipment under test. We can calculate the

- Efficiency
- Load regulation and line regulation

The value of efficiency is defined as:

$$\eta = \frac{V_o \times I_o}{P_{in}} \times 100\%$$

Where:

- V_o is output voltage,
- I_o is output current,
- P_{in} is input power

The value of load regulation is defined as:

$$Load\ reg1. = \frac{V_{FL} - V_{NL}}{V_{NL}} \times 100\%$$

Where:

- V_{FL} is the output voltage at 100% full load
- V_{NL} is the output voltage at 60% full load

$$Load\ reg2. = \frac{V_{FL} - V_{NL}}{V_{NL}} \times 100\%$$

Where:

- V_{FL} is the output voltage at 60% full load
- V_{NL} is the output voltage at 20% full load

The value of line regulation is defined as:

$$Line\ reg. = \frac{V_{HL} - V_{LL}}{V_{LL}} \times 100\%$$

Where:

- V_{HL} is the output voltage of maximum input voltage at 100% full load
- V_{LL} is the output voltage of minimum input voltage at 100% full load

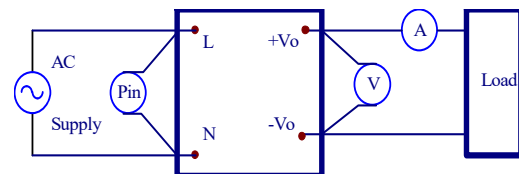

Figure 1. TRE06 Series Test Setup

4.2 Output Ripple and Noise Measurement

The test set-up for noise and ripple measurements is shown in Figure 2. Measured method:

Add a 0.1 uF ceramic capacitor and a 10uF electrolytic capacitor to output at 20 MHz Band Width.

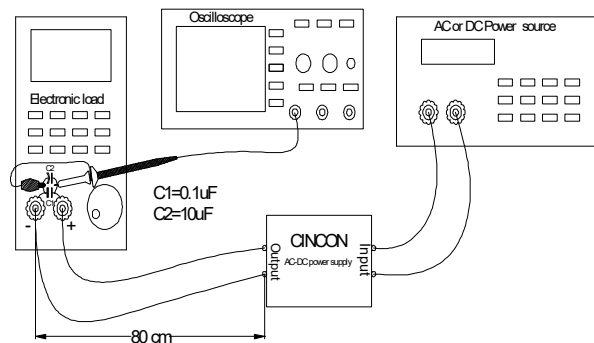

Figure 2. Output Voltage Ripple and Noise Measurement Set-Up



TRE06 Series

Application Note V12

5. Packing Information

The packing information for TRE06 series is showing as follows:

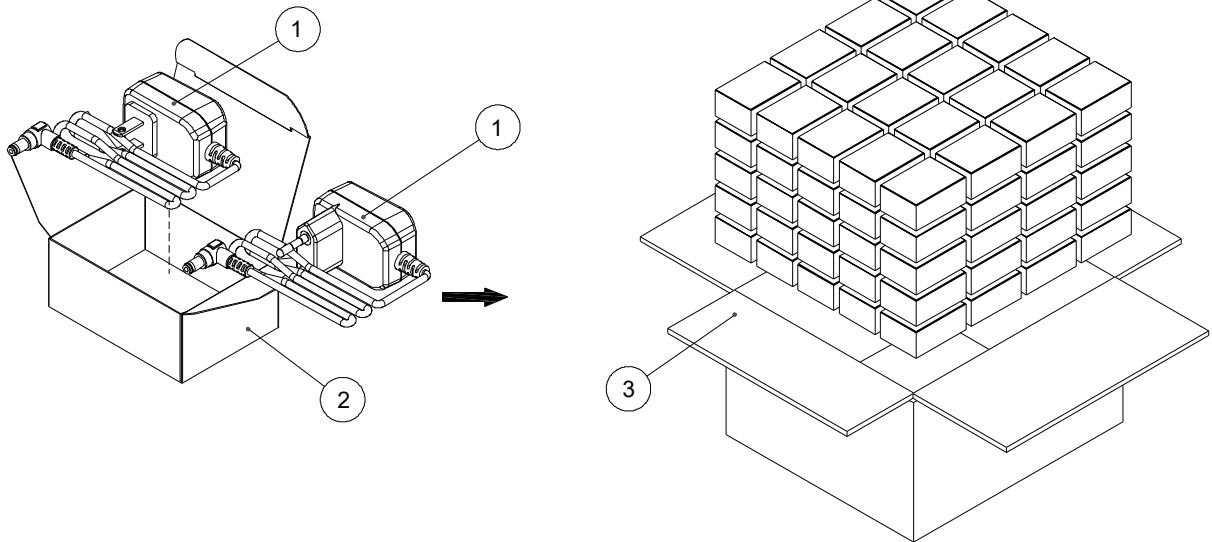

ITEM	PART NO.	NAME	OUTSIDE DIM(mm)	PCS
1	-	TRE06SXXX-A Product or TRE06SXXX-E Product	52x36x25.21mm	100
2	G64304172	Inner Box	90x65x40mm	100
3	G64114396	No.205 Cardboard Box	380x340x220mm	1

Each Box Packaging 100 PCS Products
 Net weight Ref. 5.5 Kg
 Gross weight Ref. 6.5 Kg

Headquarters:

14F, No.306, Sec.4, Hsin Yi Rd.
 Taipei, Taiwan
 Tel: 886-2-27086210
 Fax: 886-2-27029852
 E-mail: sales@cincon.com.tw
 Web Site: <https://www.cincon.com>

CINCON ELECTRONICS CO., LTD.

Factory:

No. 8-1, Fu Kung Rd.
 Fu Hsing Industrial Park
 Fu Hsing Hsiang,
 Chang Hua Hsien, Taiwan
 Tel: 886-4-7690261
 Fax: 886-4-7698031

Cincon North America:

1655 Mesa Verde Ave. Ste 180
 Ventura, CA 93003
 Tel: 805-639-3350
 Fax: 805-639-4101
 E-mail: info@cincon.com